

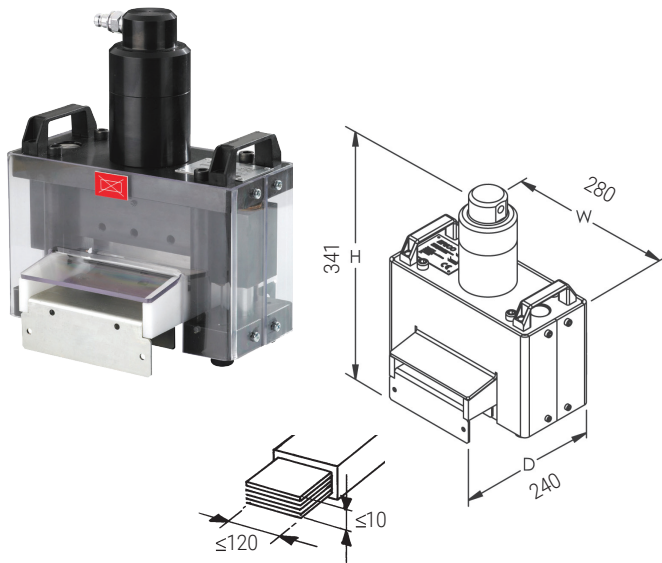

Hydraulic Flexibar Shearing Tool



- Copper or Aluminium
- Strong mechanical construction
- Cuts quickly and accurately without burrs or deformation
- Visual inspection of cutting position
- Maximum Capacity Copper cross section 1200 mm²
- Width of bar: 120 mm (4-3/4")
- Thickness of bar: 12 mm (1/2")
- Flexibar 10 x 120 x 1 maximummaximum

WARNING: Cutting solid bars will damage the tool

Article N°	Description		
559010	Hydraulic shearing tool HFST	1	34 kg
559040	Tool blades HFST-C	1	1 kg

Flexibar Shearing Tool Guide

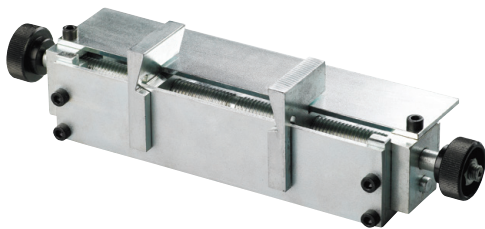

- Adjust the Flexibar position in the tool quick set up - No tool required
- Increases blade life expectancy

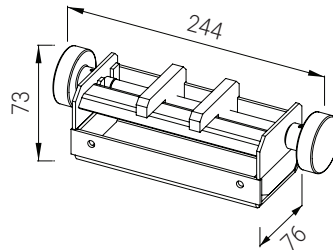
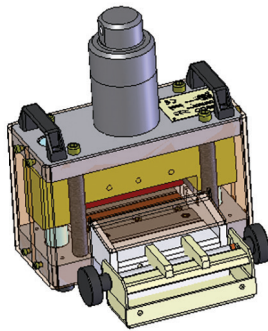

Article N°	Description		
559020	Tool Guide HFST-B	1	1 kg